

8 7 6 5 4 3 2 1

D

C

B

A

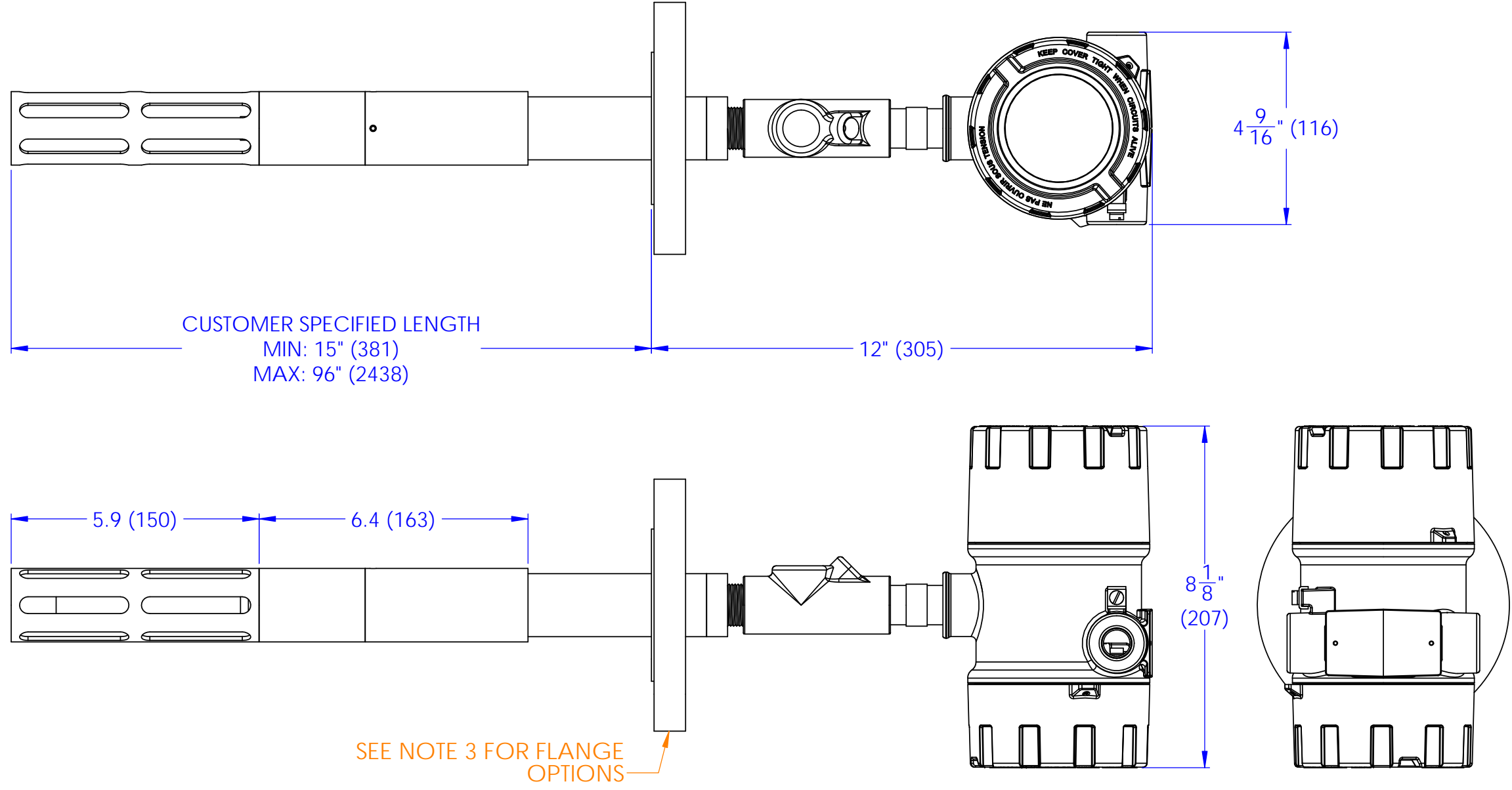

- NOTES:**
1. ALL DIMENSIONS ARE GIVEN IN INCHES (mm)
 2. FLANGE SHOWN IS 2 INCH RF BLIND WITH 1.50" BORE THRU
 3. FLANGE RATING OPTIONS ARE ANSI 150, 300, 600, OR 900
 4. ALL WETTED PARTS ARE 316/316L STAINLESS STEEL

PHASE DYNAMICS, INC.
 1251 COLUMBIA DRIVE
 RICHARDSON, TX 75081

FILE LOCATION:				UNLESS OTHERWISE SPECIFIED: MATERIAL:		TITLE: RAZOR		2-6 INCH 150-900#	
REVISION	DESCRIPTION	ECO NO.	DATE	DIMENSIONS ARE IN INCHES		NAME	DATE	DRAWN BY: CP 12/15/2016	
A	ADDED COMPOUND SEAL; MODIFIED MAT'L OPTIONS	367	3/19/2019	TOLERANCES: FRACTIONAL ±1/16" ANGULAR ±0.5°		See Parts List		ENGINEERING CHECK:	
				NEXT ASSY QNTY		WEIGHT (LBS): VARIES WITH FLANGE OPTION		Q.A. CHECK:	
				APPLICATION		DO NOT SCALE DRAWING		SCALE: 1:3	
PROPRIETARY AND CONFIDENTIAL THE INFORMATION CONTAINED IN THIS DRAWING IS THE SOLE PROPERTY OF PHASE DYNAMICS, INC. ANY REPRODUCTION IN PART OR AS A WHOLE WITHOUT THE WRITTEN PERMISSION OF PHASE DYNAMICS, INC. IS PROHIBITED.						SIZE B DWG. NO. 0070-00360-000		REV A SHEET 1 OF 1	

8 7 6 5 4 3 2 1