



# Enhanced/Expanded Wiring Guide

Document Number 0066-00003-000 REV A

1251 Columbia Dr.  
Richardson, TX 75081  
Phone: 972 680 1550  
FAX: 972 680 3262

## System Cable Wiring

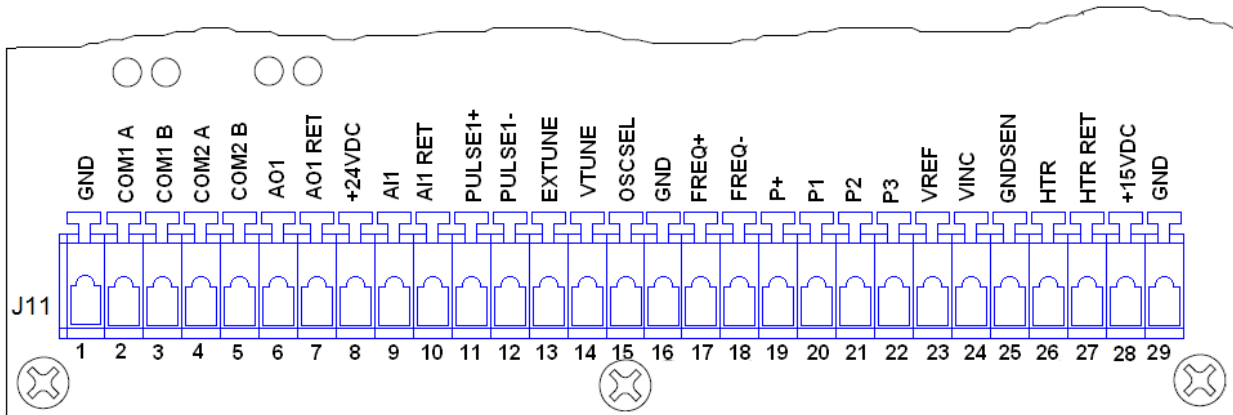

- |  |   |
|--|---|
| J11- 13: White/Yellow                              | J11-22:Violet   |
| J11-14: White/Green                                | J11-23: Blue  |
| J11-15: Yellow                                     | J11-24: Green   |
| J11-16: Drain of "White/Red and White/Orange" pair | J11-25: Brown   |
| J11-17: White/Red                                  | J11-26: Orange  |
| J11-18: White/Orange                               | J11-27: White/Black                                     |
| J11-19: White/Brown                                | J11-28: Red   |
| J11-20: White                                      | J11-29: Black and Drain of "White/Green and Brown" pair |
| J11-21: Grey                                       |   |

## Analog Input Wiring

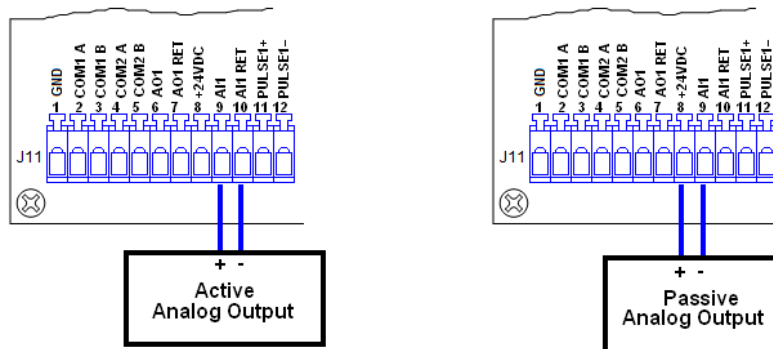

**Touch Screen Cable to Push Button Connections**  
 SELECT: Orange  
 MENU: Brown  
 ENTER: Violet  
 VALUE: Green

**Connection to touch-screen**  
 Positive: Grey  
 Negative: Blue  
 Prot. Earth: Black  
 Com2 RDA: Red  
 Com2 RDB: Yellow

## Green Grounding Wire

Connect the provided Green Ground wire between the Explosion-Proof enclosure and the Oscillator enclosure

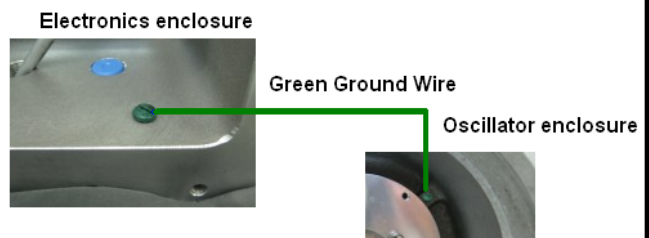
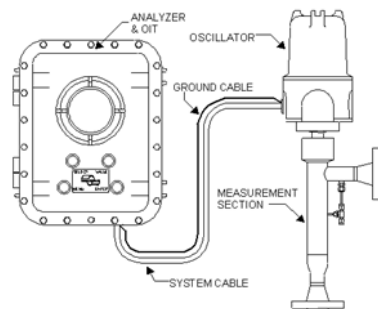

## Active Only Analog Output And HART Communication Wiring

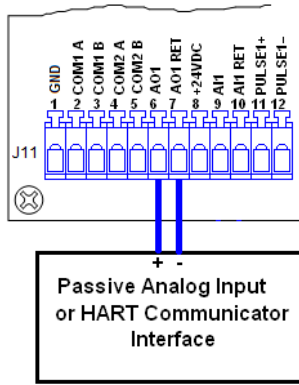

## Communication Ports Wiring

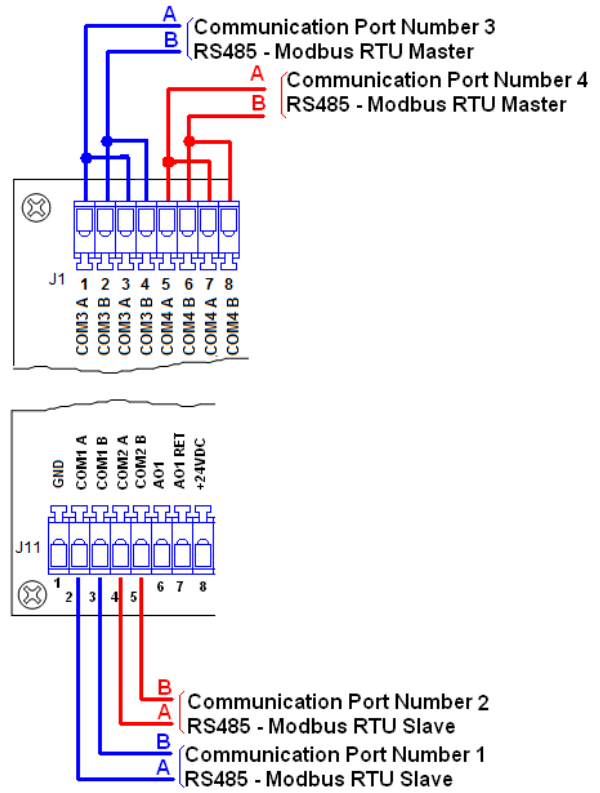

## Relay 1 and 2 Wiring

Fused independently. 1A/125 V Capacity

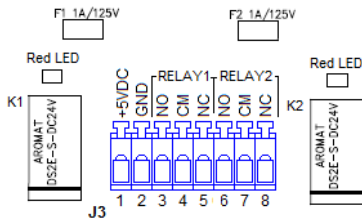

## Pulse Input Wiring

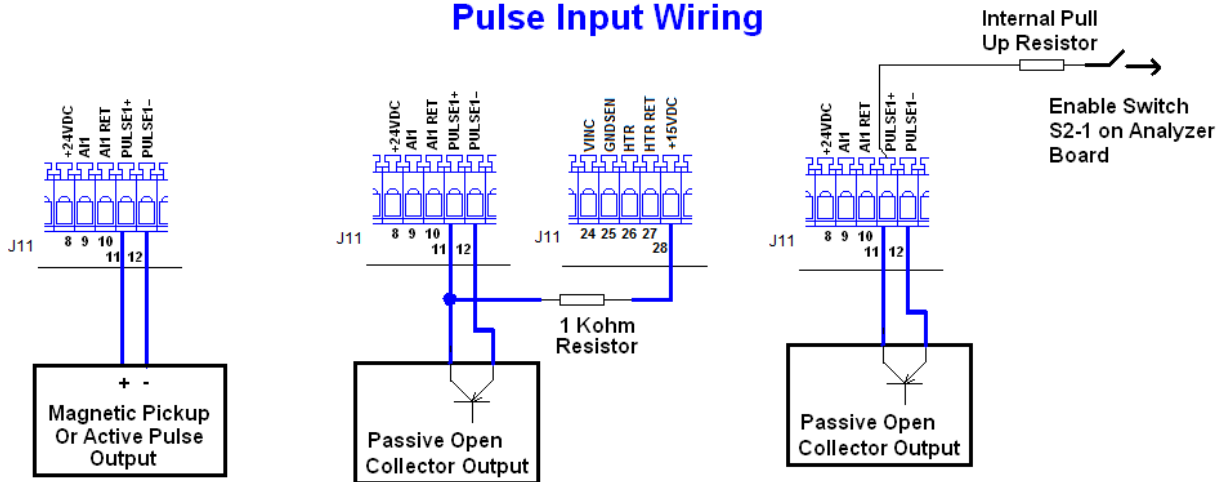

## Expanded Analog Inputs (2 to 5)

Analog Inputs 3, 4 and 5 should be connected in the same way

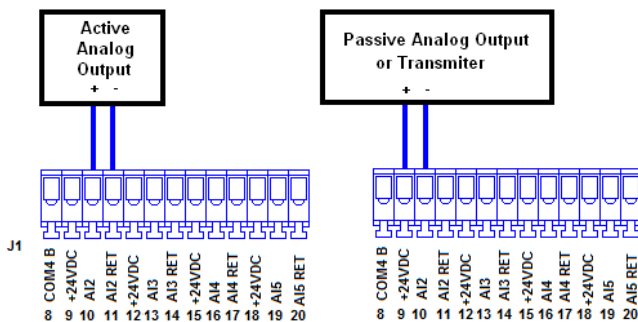

## Active Only Expanded Analog Outputs (2 to 5)

Analog Output 3, 4 and 5 should be connected in the same way

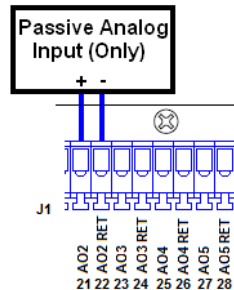

## Expanded Pulse Inputs 2 and 3

There is no Internal Pull Up resistors for these inputs. In case of a Passive Open Collector output, please use an external 1KOhm resistor as shown for Pulse Input 1

