

DWG NO. 0070-00196-000 REV B SH 1/1

REV	DATE	ECO	COMMENTS
A	06/04/02	156	CHANGED GROUND CAGE
B	06/04/03	169	ADD METRIC UNITS

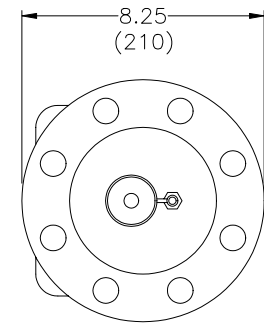
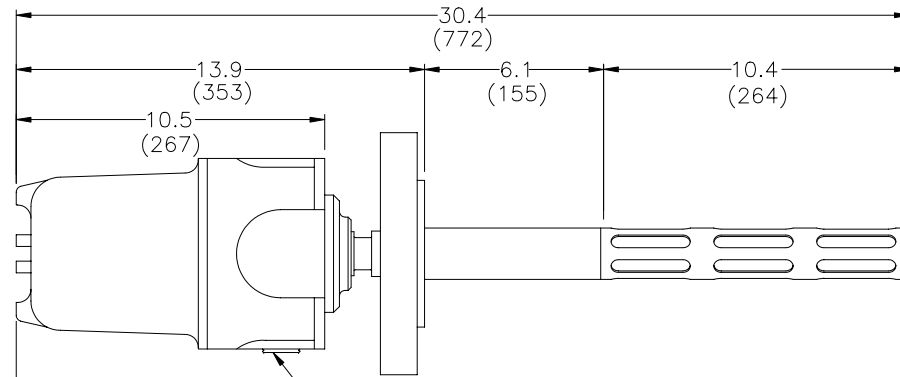
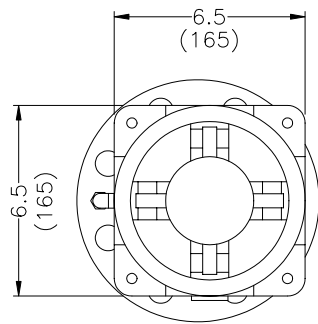
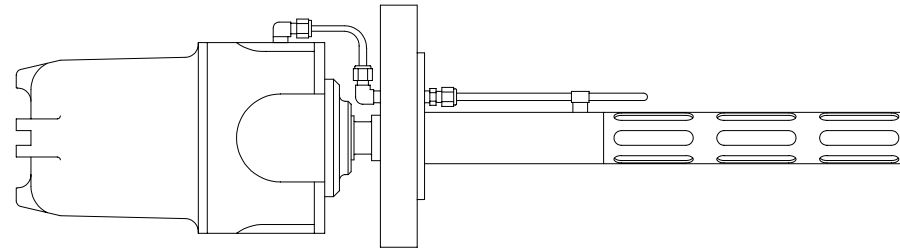

18 (457)  
RECOMMENDED MINIMUM CLEARANCE FOR ACCESS

0.75-14 NPT REDUCING BUSHING (SUPPLIED)

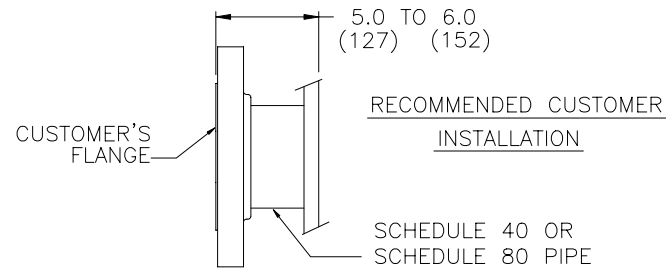

- NOTES:
- 1 FLANGE IS 3 INCH, 316L STAINLESS RAISED FACE ANSI 300
  - 2 RECOMMEND CUSTOMER INSTALL FLANGE FROM 5.0 TO 6.0 INCHES FROM VESSEL INTERNAL WALL. (NOTE UNIT LENGTH)
  - 3 WEIGHT: 38 LBS (17kg)
  - 4 ALL DIMENSIONS GIVEN IN INCHES MILLIMETER DIMENSIONS SHOWN IN ( )

 <b>PHASE DYNAMICS, INC</b> RICHARDSON, TEXAS	
TITLE <b>3 INCH 300# INSERTION TYPE TEMP PROBE, 10 IN CAGE</b>	
SIZE <b>B</b>	DWG NO. <b>0070-00196-000</b>
REV <b>B</b>	DATE <b>07/16/01</b>
© PHASE DYNAMICS, INC.	